

24V C.C. - D.C.

**VA18-BP51/C-41A
VA18-BP51/C-41S**

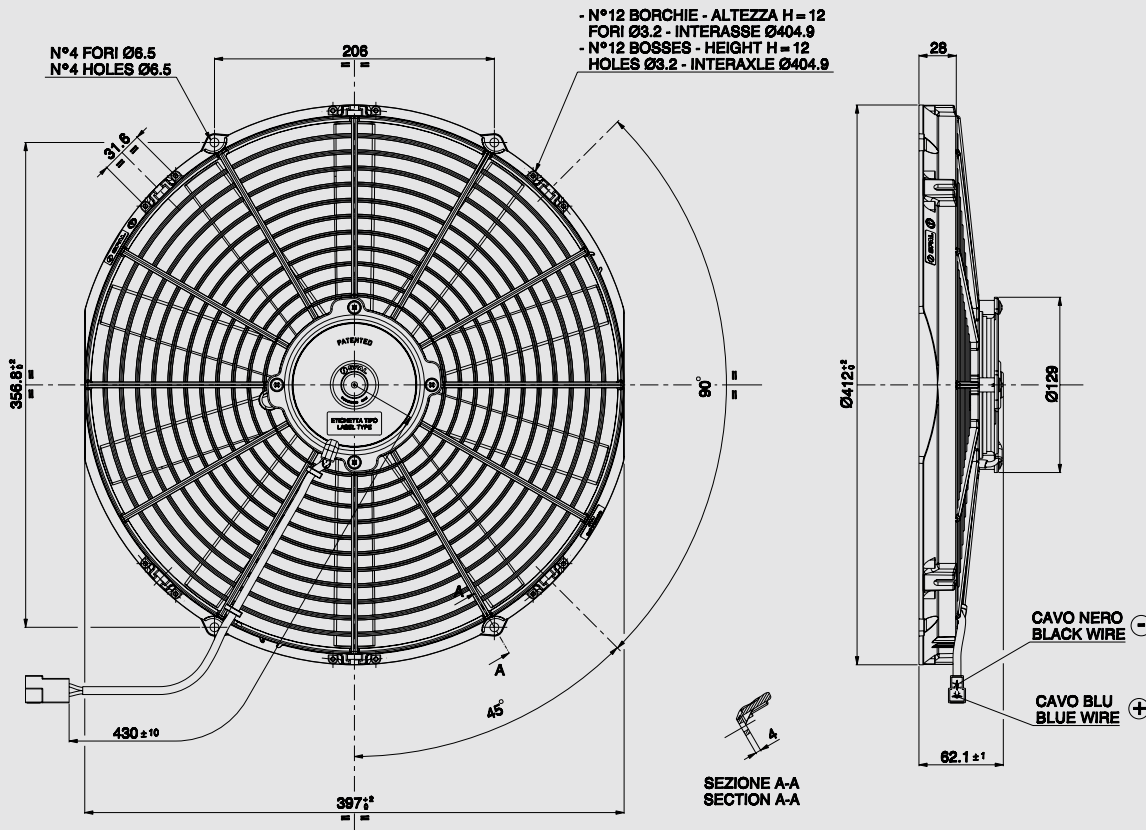

AMP connector Code 180908
 AMP terminal Code 42098-2
 Suggested mounting torque: 3(+1/-0) Nm with screw M5
 Weight 1,75 Kg. approx.

Connettore AMP Cod. 180908
 Terminali AMP Cod. 42098-2
 Coppia di serraggio consigliata: 3(+1/-0) Nm con vite M5
 Peso 1,75 Kg. circa

Ø 385 mm

Ø 16"

suction / aspirante

blowing / soffiante

PRODUCT FEATURES
CARATTERISTICHE PRODOTTO

Static pressure Pressione statica mm H ₂ O	suction / aspirante			blowing / soffiante			Static pressure Pressione statica inH ₂ O
	Airflow Portata m ³ /h	Current input Corrente assorbita A	Airflow Portata CFM	Airflow Portata m ³ /h	Current input Corrente assorbita A	Airflow Portata CFM	
0	2480	5,5	1463	2640	5,2	1558	0
2,5	2310	6,0	1363	2590	5,6	1528	0,1
5	2160	6,0	1274	2260	6,0	1333	0,2
7,5	1980	6,1	1168	2000	6,1	1180	0,3
10	1770	6,3	1044	1740	6,1	1027	0,4
12,5	1430	6,2	844	1440	6,2	850	0,5
15	1050	6,0	620	1120	6,1	661	0,6
17,5	810	5,9	478	980	6,1	578	0,7
20	610	5,9	360	550	5,7	325	0,8
25	0	5,8	0	0	5,5	0	1

Waterproof motor, IP 68 Motore chiuso, IP 68	✓
Long life / Lunga durata	✓
LL and VLL version* Versione LL e VLL*	✓
Waterproof connector Connettori a tenuta stagna	✓
Accessories: all the fixing kits Accessori: tutti i kit di fissaggio	✓

* for OEM applications only.
* per applicazioni OEM

✓ = Standard feature
 Caratteristiche standard
 ✓ = Available upon request
 Disponibile su richiesta

Test voltage 26 V. D.C. - Tensione di prova 26 V. c.c.